

The Webcast model for workplace learning resource creation and professional social networks

IWBL Cyprus symposium 23-26 June 2010

Dr Anthony 'Skip' Basiel abasiel@gmail.com, pros@mdx.ac.uk

Dr Mike Howarth michael.howarth@mhmv.com

Skip: 07771 998 799

Mike: 07778 537 505

Institute for Work Based Learning  Work Based Learning
at Middlesex University

Webcast computer View

Controlled by online text discussion moderator

Camera and Voice

wbw4offline.jpg

Production
Presenter:
Dr Anthony 'Skip' Basiel
pros@mdx.ac.uk
00 44 (0)7771 99 87 99

Producer:
Dr Mike Howarth
michael.howarth@mhmvr.com
00 44 (0)7778 537505

Webcast moderator:
Braulio Oliveira
Video: Goolshun Balut,
Daryl Sobers

News Questions Experts
10.00 -11.00 GMT
6th May
13th May
3rd June
10th June
1st July
8th July

First and second
Wednesdays
each month

Business Development Team
Telephone: 0208 411 5050
Email: business@mdx.ac.uk

Research
Skip:
elearning.mdx.ac.uk
Mike:
http://www.mhmvr.co.uk

OFFLINE !

Work Based Learning
at Middlesex University

**WORK BASED WEDNESDAYS
WEBCAST**

Chat

Wendy Oliveira: please ask us questions in the chat window
Carol: Do I need a BA?
Wendy Oliveira: Work Based Learning (WBL) has many variations, at Middlesex University this is defined as learning that permits a flexible learning experience that is delivered through work, in-work, for work.
Wendy Oliveira: The qualification you gain through work based learning has the same value as if you had gone to university in the traditional way. It's just a more intensive way of learning where both the you and your organisation can benefit.
Anasth: It has holds a master degree and has working working experience, how many modules are needed to complete a one's master's learning master's level?
Wendy Oliveira: For masters degree: 600 credits is required
Shirley Brown: Following on from your point about using WBL, qualifications is possible for other degrees, can you use a portfolio created through WBL to help gain entry to other MBA degrees too if you do not have an undergraduate degree but want to do an MBA can you submit a WBL portfolio to gain entry?
Wendy Oliveira: The next Work Based Learning web cast will take place on 1st March 2009 at 10am GMT
Wendy Oliveira: WBL Open Evening on 4th March 2009, 17.00-19.00 at London WBL
Wendy Oliveira: www.wbl.ac.uk/eng
Wendy Oliveira: please use your experience to help to improve the service
Wendy Oliveira: You can call us now on 00 44 (0)207 131 0500 Participant Code: 587701#
Wendy Oliveira: We apologise for the response speed here, this will be back up soon
Wendy Oliveira: Can you please complete the survey to help us to improve the service
Carol: Bye and thank you
Carol: re: what is your
Wendy Oliveira: thank you to all
Braulio: Mike: I just joined across this one

Attendee List (3)

My Status: Active

- Skip Basiel
- Prof. Carol Costley
- WBL Wednesdays Online

Presenter and interviewee

Slides or video

- 1: Questions from attendees
- 2: Specific advice from moderator
- 3: Private messages from moderator to presenter

General information to attendees

Adobe Connect

Adobe Connect: Online Live screen view

The screenshot displays the Adobe Connect meeting interface. At the top, there are 'Meeting' and 'Help' tabs. The main area is divided into several panels:

- Camera and Voice:** Shows a video call with two participants. The left participant is identified as 'Edward - Jessica - Ralph' and the right as 'Dr. Anthony 'Skip' Basiel'. A logo for 'Work Based Learning at Middlesex University' is visible in the background. Below the video, there is a 'WBL Wednesdays' icon.
- Note:** Contains the text: 'You can call us now on 44 (0)207 131 0500 Participant Code: 587701#, alternative you can join us on the live chat text.'
- Attendee List (21):** Shows 'My Status: Active' and lists two attendees: 'Karen Gittins' and 'Karo'.
- Chat:** Contains the following text:

Bachelor of Arts (Hons)
Professional Practice
David: There is lots of good work going on in your school. What do you see as its strengths at the present time?
David: That was a question for Ed plesae.
WBL Wednesdays: thank you for your question david, we will get this to Ed shortly
- WBLpresentation 22ndjune:** A presentation slide with the following content:

The Institute for Work Based Learning
Middlesex University
College House
The Burroughs
Hendon
London NW4 4BT
Telephone: 020 8411 5050
Email: business@mdx.ac.uk

We offer
Work Based Learning
at every level of
Higher Education
and
Accreditation
of your
in-house
programmes

A flexible learning experience that is delivered through work, in work, for work.

NOW LIVE !

WORK BASED WEDNESDAYS
WEBCAST

The concept:

- 1) Selling the £ 8m MODNet (Middlesex Organisational Development Network) Project Work Based Learning message to staff internally and businesses externally.
- 2) WBL Staff + Deans from each of the schools + WBL students peer to peer advice

The production sequence:

- Phone call to discuss interview - two weeks before
 - Title for webmail.
 - List of questions
 - Second speaker + (guest alumni?)(contact info).
 - Recommended email contacts for webmail.
- Interview guide/extra advice provided
- Arrive Quad reception 11.30 - Live 12-1
- Off air post recording 15min

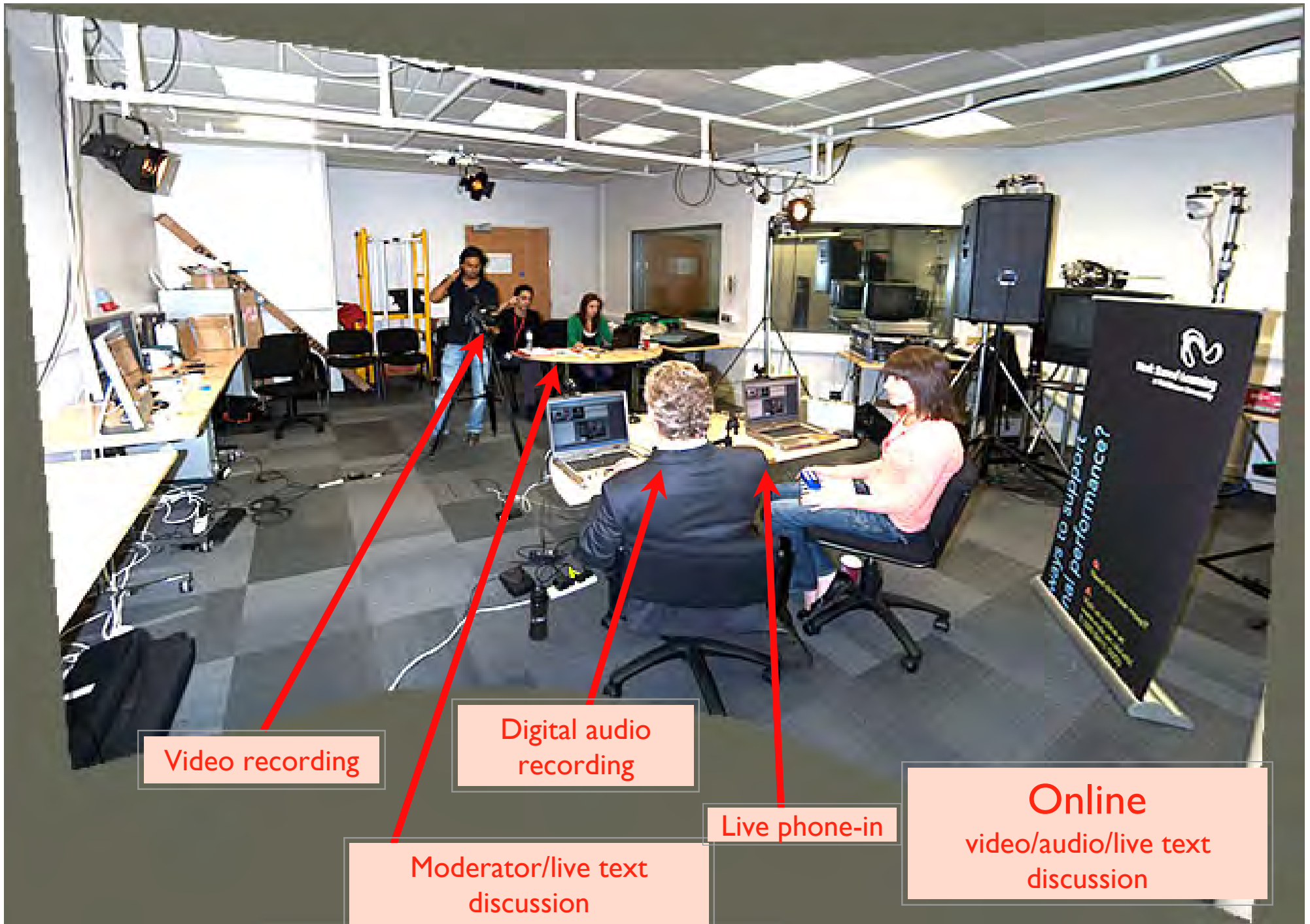

Video recording

Digital audio recording

Moderator/live text discussion

Live phone-in

Online video/audio/live text discussion



Moderator/live text discussion/text in and out/powerpoint/text recording

Online mics

Online audio monitoring

Radio mics

Webcams

Video recording

Lighting

Webcast Adobe Connect set up Diagram

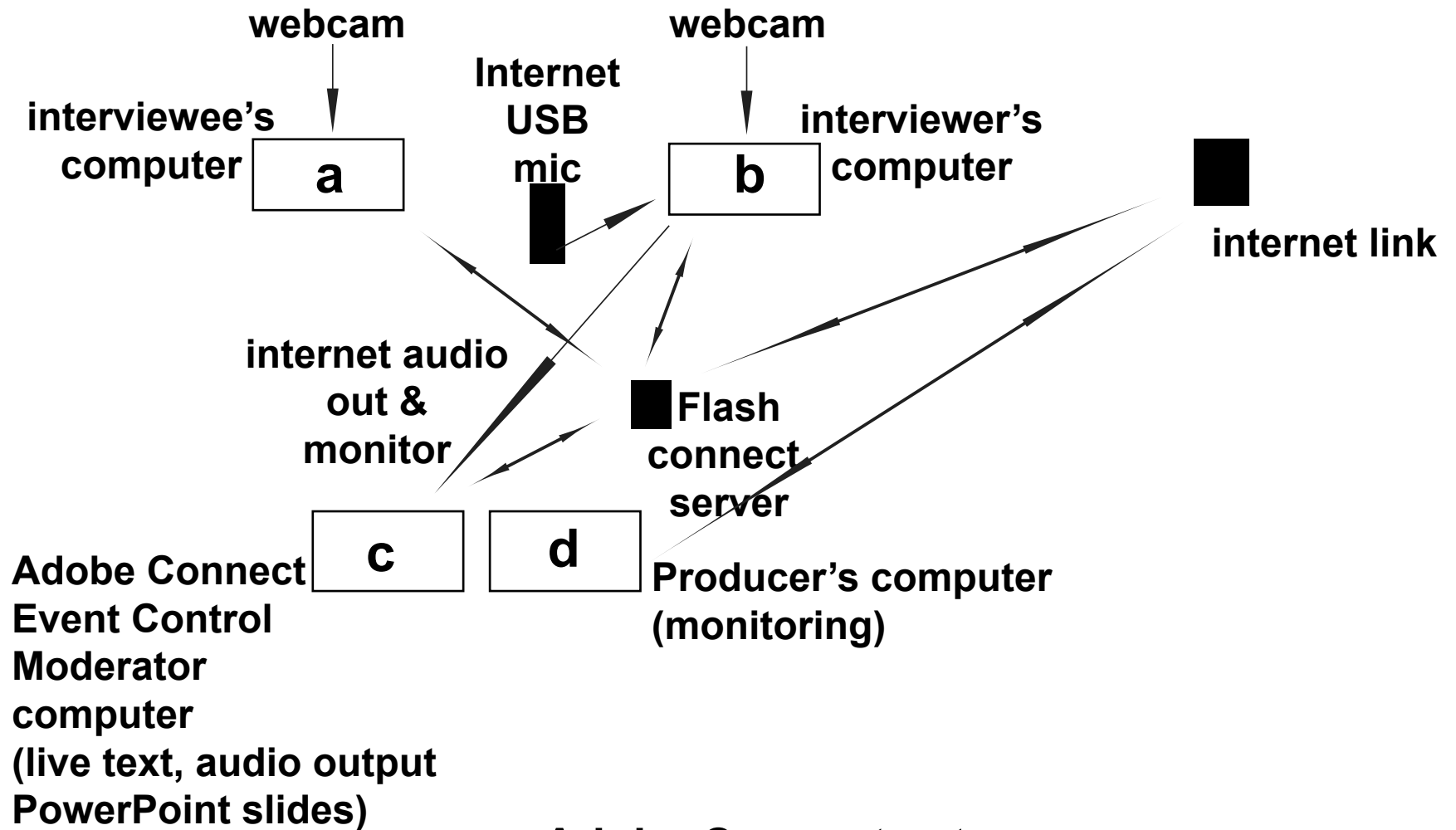

Adobe Connect set up sequence

- 1) Computer a,b,c set up sequence.
- 2) c sets up as host and gives host status to a, b.
- 3) a, b switch on webcams and switch off mics.
- c) a sets up usb mic on b.

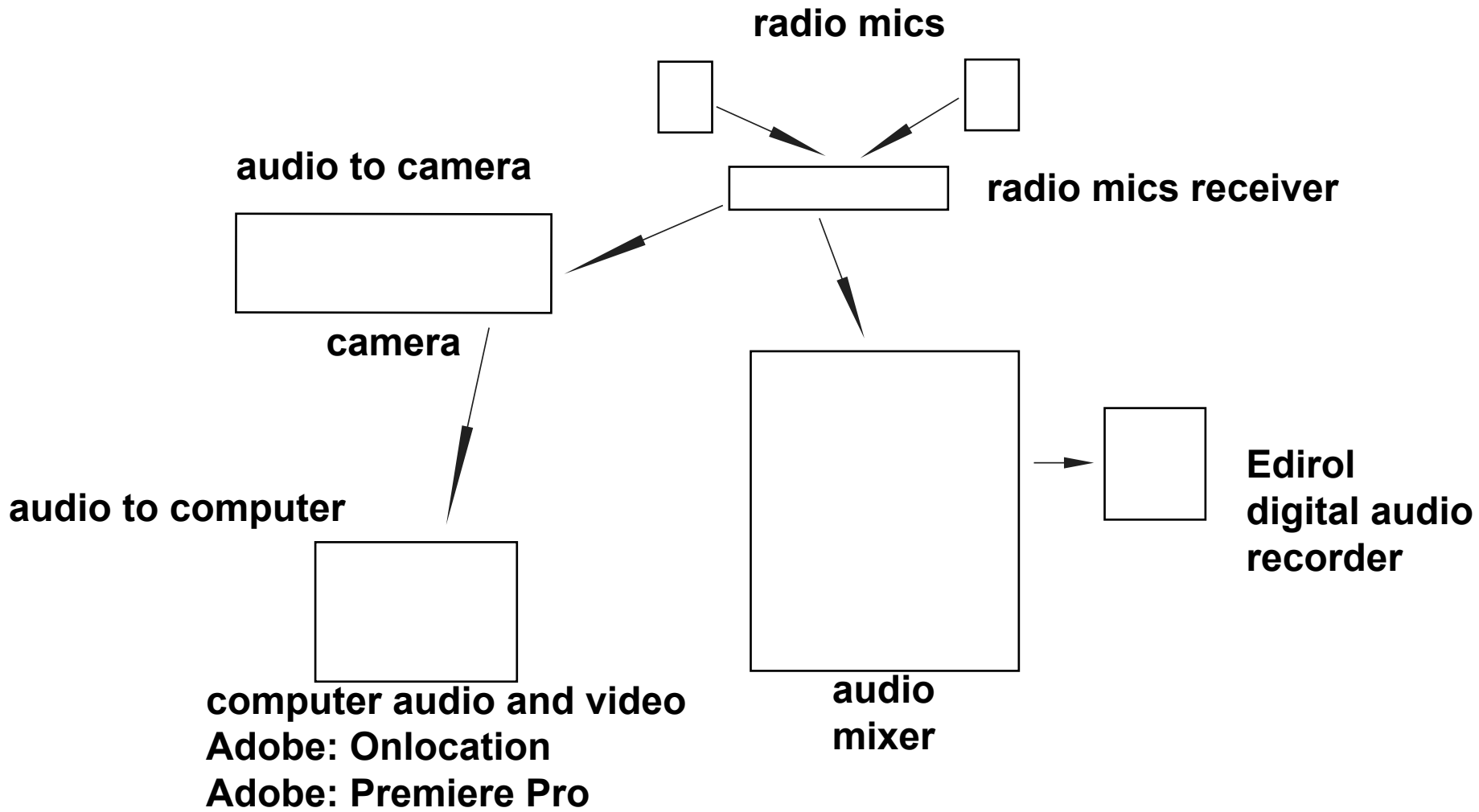

Webcast Audio Recording Output Diagram



The key = good organisation - the producer's red book

The Red Book: producer's paperwork



11.30 Guest arrives- run through/mic up



Final system check: 11.45 - live at 12 noon - 1pm



Post broadcast: Highlights record to camera

webcast + webmail/html email

Next webcast content

PR links

Contact info

Video links to MU TV (scroll down)

Work Based Learning at Middlesex University

WBL WEDNESDAYS WEBCAST

WEDNESDAY 30TH SEPTEMBER 2009

Work Based Learning Wednesday Webcast 7th October: 12 noon - 1.00pm

"Work Based Learning for your staff"



David Williams Head of Business Development for the Institute for Work Based Learning is the speaker for the first of our webcasts of the year.

Click [here](#) to express interest in taking part in the free easy to use Adobe Connect webcast on the 7th Oct.

Join the event on the day by clicking [here](#)

How your company can benefit

David Williams will welcome your live text discussion questions

IN THIS ISSUE

MODNet Latest links

- [MODNet News Blog](#)
- [IWBLMU \(IWBL web channel\)](#)
- [IWBL bookmarks](#)

Also this month

Talent Management

Wonder how this can be the next best think for your company. We think it is. [Read More »](#)

Wonder how this can be the next best think for your company. We think it is. [Read More »](#)

Look Behind the Scenes

Work Based Wednesday TV [etc. Read More »](#)

This is a web email

To discuss how Work Based Learning applies to you contact the Business Development team or call 020 8411 5050. [Read More »](#)

The Webcast model for workplace learning resource creation and professional social networks

The Webcast model for workplace learning resource creation and professional social networks

Dr. Anthony 'Skip' Basiel, Dr. Mike Howarth – IWBL, Middlesex University

pros@mdx.ac.uk

Anthony 'Skip' Basiel is a Sr. Learning Development tutor and eLearning researcher at the Institute for Work Based Learning, Middlesex University specialising in online pedagogy, web video conferencing and professional social networks. Please see:

<http://www.elearning.mdx.ac.uk/research>

Mike Howarth, a former BBC radio producer, is an eLearning consultant on several IWBL projects. Find out more at: <http://www.mhmv.co.uk/>

Introduction

We were given the challenge to find innovative ways to support and promote the learning processes associated with the activity of current and successful graduates of Work Based Learning (WBL) at Middlesex University to a world-wide audience. This task needed to be done with our existing resources; web video conferencing (Adobe Connect), landline phone conferencing and digital video recording/editing systems.

Traditional tutor-generated style module handbooks delivered content and procedural support to prospective and current learners. Our aim was to provide live interviews of WBL experts and Professional Doctorate graduates through interactive webcasts and phone call-ins. We wanted to get to the heart of their story, not broadcast a sales pitch. The interviews were recorded and edited to create

Our professional social networked (PSN) eLearning model sees the webcast event as on part of a triad design. Next, the interview discussion topics are related to an eBook chapter which provides more detailed argument. This short, easy-to-read and practice-focused PDF can be printed as well. Thirdly, a face-to-face presentation and workshop opportunity allows participants to delve even deeper into the issues introduced in the webcast and eBook. These events are supported by a website providing pre-and-post event resources / learning activities. Figure 1 illustrates our PSN eLearning model.

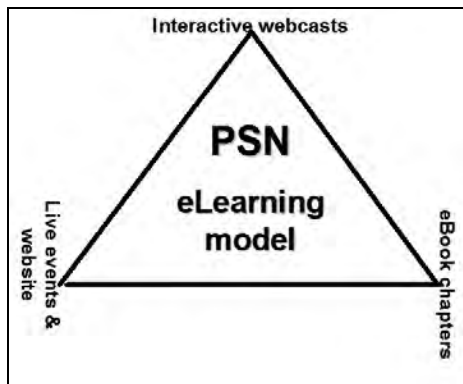

Figure 1 PSN eLearning model elements

Our eLearning case study for work based learners has made us aware of a digital learning spectrum (Basiel, A. & Howarth, M. & Commins R. 2008). The elements we explored are quality of the production of the eLearning resources (e.g. video recordings) [vertical 'y' axis], the degree of pedagogical engagement of the eLearning event stakeholders or the degree of 'client centeredness' [horizontal 'x' axis], and the degree of motivation for the audience using the webcasts, eBooks and workshops [diagonal 'z' axis]. Figure 2 shows how each element can have a low-medium-high range in the spectrum.

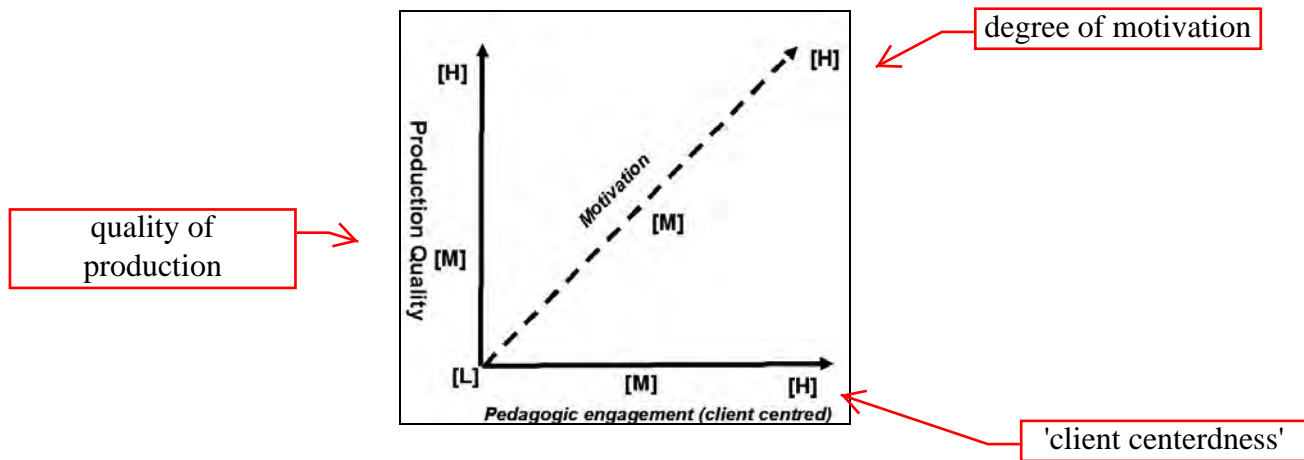

Figure 2 PSN model elements

When we overlay the new media components of the 'rapid ePublishing' model for the PSN from Figure 1 and the elements of the eLearning spectrum we can see how these threads weave together to create Figure 3.

When we overlay the new media components of the 'rapid ePublishing' model for the PSN from Figure 1 and the elements of the eLearning spectrum we can see how these threads weave together to create Figure 3.

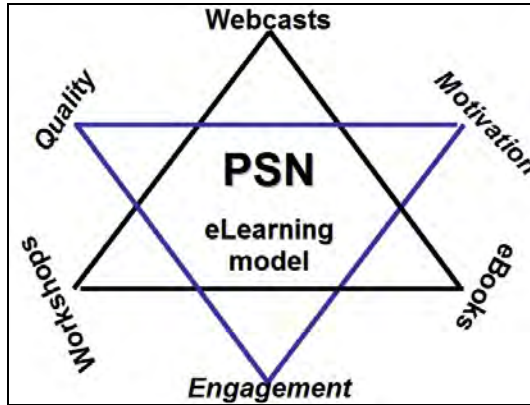

Figure 3 Composite of PSN eLearning issues

PROs and CONs of Adobe Connect:

Discussion - Questions

Mike Howarth 07778 537 505

01992 587292

Skip Basiel 07771 9987 99

0208 4418532

APPENDIX 1: Briefing document to contributors

Quality preparation is essential for a good product

Information needs to come to the producer on time.

Contributors and PAs have all the details sent well in advance.

Absolute final deadline: the Friday before webcast date.

- 1) A title, four lines of blurb for each talk and your photo, ready for PR webmail distribution on the Monday advertising the webcast to 1,000 + .
- 2) To get the idea how little is effort is needed see here: <http://www.mhmvr.com/wbwwmail>
- 3) But the webmail text is vital PR and focus for your preparation for the interview.
- 4) You will be interviewed. All introduction, info and links are handled in a script. In a changeover from one speaker to another, there will be a pause while the interviewer talks to camera.
The speaker leaves the chair, the radio mic changed and the next person is introduced.
- 5) A list of ten short questions with bullet point answers sent to the producer (well in advance) give you both a chance to prepare and allow Skip to support you to sell the message develop a quality message.
- 6) The 'second person' needs the same list: a photo, brief webmail outline and list of questions.
Please see the excellent results of Ed J Esche's 'second person' on MDX Play
- 7) **Ideas for post online 'to-camera' video:** Prepare a brief list of key points perhaps selling the School's wbl facilities and second person' positive experience of the wbl experience. See the quality that we are achieving. <http://www.play.mdx.ac.uk/videos/4lxc>
We are finding that interviewees do these interviews quickly as they have 'rehearsed' their theme during the online interview.
Tips for to-camera: look at the camera or slightly off to the interviewer, wait 4 seconds before answering, repeat the key elements of the question so it can be edited out, duration 2min - ish: main theme and an example, end smile and gentle gaze to camera for 4 seconds.
Please Note: from 9th Dec week each webmail has links to previous week mdx play and audio podcasts. Extra valuable publicity!

APPENDIX 2: List of Gear

3 computers

3 web cams

Online Mic: Rode Podcaster Broadcast Quality USB Microphone

Mixer: Yamaha MG82cx

Audio recorder: Edirol R-09H

Radio Mics: Shure PG185 Condenser Lavalier

Video Camera: Sony PD-150

Adobe Connect dedicated server

Mac Onlocation software

1TB external backup drive

MINI DV 80min camera set to DV SP

Backdrop + poles

Lights